

# SC-4

## SYSTEM CONTROLLER



SC-4 is the powerful control system at the heart of a Utah Scientific routing switcher system. In addition to controlling any of the current or legacy Utah routing switchers, SC-4 can also provide interface capability to many third party control and switching systems. Because of its modular design and advanced software, SC-4 can easily adapt to any application, from simple stand alone applications to the most sophisticated control systems.

Matrix switching is executed using the advanced UCP and SCP Series control panels, the earlier CSP/4 Series control panels, or a wide array of computer, remote, custom or networked control capabilities.

SC-4 provides enhanced control for the UTAH Series routers and also allows you to integrate your current 3rd party switcher into the UTAH Series routing system. This means your past investment is protected while the UTAH Series routing system gives you all the benefits of the new control system technology.

### SC-4 FEATURES

- Compatibility with all Utah routing systems and control panels - Protects your earlier investments.
- Increased Matrix Size Capacity - Allows for future growth (1152 x 1152 x 16 levels).
- Comprehensive SNMP monitoring functionality.
- Graphical User Interface (GUI) applications for configuring, managing, and operating the system.
- Triple Sync Inputs - Supports SD(NTSC and PAL) and HD vertical blanking interval switching.
- Tie Line Management Feature – Simplifies multi-format routing.
- Redundant Control and Power Supplies in the Same Frame - Preserves valuable rack space.

## System Connections

The SC-4 has both the control and power necessary to reliably manage the increasingly complex world of analog, digital and HDTV signal distribution. SC-4 enables users to centrally control and monitor all multi-format routers and master control switchers from the same control network.

Eight U-Net control panel ports provide high speed connections between the UCP and SCP Series control panels and the SC-4 controller. Industry standard RJ45 connectors allow quick and easy wiring of the control panels.

The Ethernet ports allow network connections using standard Ethernet LAN topologies. The Ethernet interface is used for making system configuration changes via the U-Con system configuration utility or for remote routing switcher control. A 10/100-baseT connection allows the use of standard Ethernet devices for interfacing to the SC-4. This interface, along with a published control protocol provides the user with almost limitless control application capability.

Six RS-232/422 serial control ports allow remote computer control and/or automation software control of the SC-4 control system. In addition, these serial control ports can be used to communicate with third party routing switchers and external devices such as Under Monitor Displays and tally control systems.

The MX Bus is a high speed control link that connects the SC-4 to the UTAH Series routing switchers. The MX Bus has sufficient speed to switch up to 128 outputs in 1 vertical interval.

*PLEASE NOTE:* To fully integrate external routers, including the legacy Utah routers, into an SC-4 control system, it may be necessary to use the MX-Lator Control Translation Unit. For more information on this option, please refer to the MX-Lator Product Information Sheet.

The Alarm Connector provides external connection of the SC-4's internal operating alarms including power supply voltage and temperature and CPU failure alarms. The GPI/O connectors allow for the connection of contact closures to provide remote control of certain operations of the SC-4 such as changeover between the main and backup controller boards.

Three Sync Reference inputs for SD (525/625) and HD signals are used to generate a SMPTE RP168 compliant switch command that switches the crosspoints during the vertical blanking interval. The SC-4 and associated MX Bus can execute vertical blanking interval switching referenced to any combination of the three reference signals in the same UTAH-Series matrices.

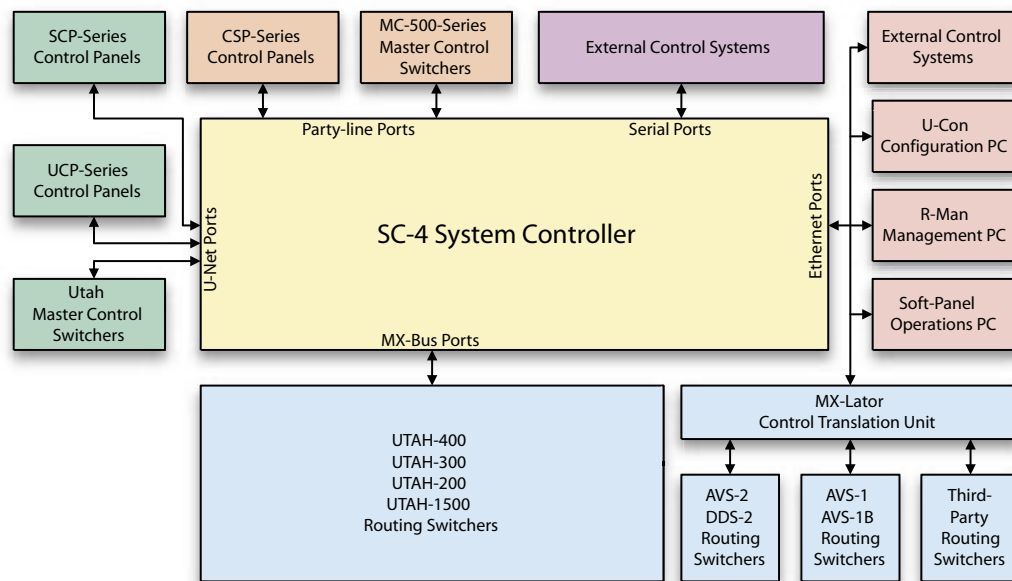

Four party-line ports provide control of the wide selection of CSP/4 Series control panels. The party-line ports can also be used with the MC-500 Series of master control switchers. New or existing systems can use a combination of the CSP/4 control panels connected to the party-line ports and the SCP and UCP Series control panels connected to the U-Net or Ethernet LAN ports.

Four party-line ports provide control of the wide selection of CSP/4 Series control panels. The party-line ports can also be used with the MC-500 Series of master control switchers. New or existing systems can use a combination of the CSP/4 control panels connected to the party-line ports and the SCP and UCP Series control panels connected to the U-Net or Ethernet LAN ports.

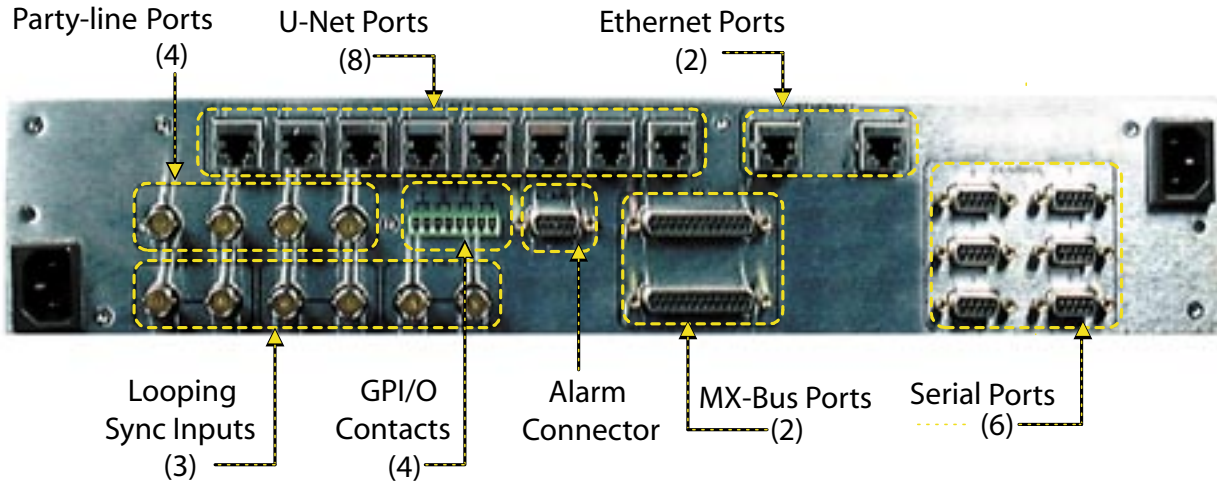

### SC-4 Control System Software Utilities

The SC-4 and SC-400 System Controllers are powerful control system processors designed to provide state-of-the-art functionality in configuring, managing, and operating a Utah Scientific Routing Switcher system. User interface for the controllers is provided by a suite of software utilities that are specifically designed to allow the user to take full advantage of the sophisticated capabilities of these controllers.

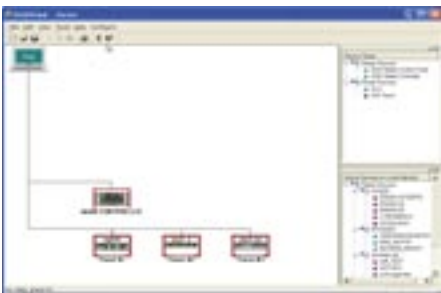

#### U-CON System Configuration Utility

U-Con is a graphically-based system for configuring the devices that make up a router control system. U-Con offers such advanced features as auto-discovery of connected devices, unlimited duplication of devices, copy and paste operation, and auto-replicate functions to make it easy to define a system configuration and very simple to make the changes that are required in normal operations

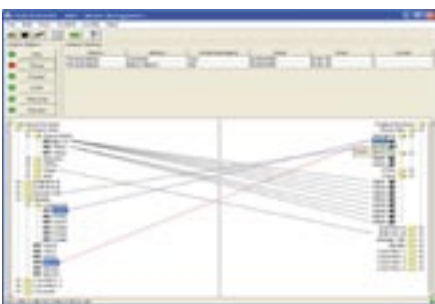

#### R-Man System Management Utility

R-Man provides a central management console for monitoring and managing the operation of the routing switcher system. Features include complete alarm management capabilities, event logging, status monitoring, and router control. Thanks to the UTAH-400 router's advanced alarms, including signal presence detection on inputs and outputs, R-MAN is capable of taking system management to new levels of flexibility with automatic protection switching and re-routing features.



#### SoftPanel-1 and SoftPanel-2 GUI Control Panel Options

The SoftPanel products offer GUI-based control surfaces for operating the Utah routing switcher systems. With advanced features such as router snapshot and salvo capabilities, SoftPanel can be a useful tool for system management as well as for normal operator functions. The SoftPanel displays are fully configurable to show all or part of the connected matrix.

## SC-4 Technical Specifications

Mechanical Dimensions:		19"W x 22" D x 3.5"H (2 ru EIA rack mount)
Connectors:	Sync:	BNC (3 ea looping inputs for analog PAL, NTSC, or HD (tri-level) sync signals)
	Network Ports:	RJ-45 (2 ea Ethernet, 8 ea U-Net)
	GPI/O Connector:	Terminal Strip (four pairs of contacts)
	Alarm Port:	DB-9F Subminiature 9-pin D connector with female pins.
	Serial Control Ports:	DB-9F Subminiature 9-pin D connector with female pins (6 ea)
	MX-Bus Ports:	DB-25F Subminiature 25-pin D connector with female pins (2 ea)
	Party-line Ports:	BNC (4 ea)
Environmental:	Temperature: Relative Humidity:	10-40°C 0-90% (non-condensing)
AC Power:	110 / 240VAC 50 / 60 Hz	Chassis consumption is 35 VA max. Dual redundant power supplies are standard equipment.

### Advanced Control System Capabilities

In addition to basic control system functions, the SC-4 System Controller supports a wide range of advanced functions such as tie-line management, global routing of dispersed matrix installations, comprehensive SNMP monitoring functionality, and many more.

Contact your Utah Scientific representative for details on these advanced features of the SC-4 System Controller.

### SC-400 Small System Controller

Much of the power of the SC-4 System Controller is available for small routing systems in the form of the SC-400 Small System Controller. Designed for use in the UTAH-200 and UTAH-400/64 routing switcher frames, the SC-400 is a direct replacement for the earlier SC-200, adding compatibility with the new range of control panels and software utilities to these small matrix solutions.

#### FOR FURTHER INFORMATION

on the individual products in the Router Control family, please refer to the detailed data sheets that are available on our Web Site:  
[www.utahscientific.com](http://www.utahscientific.com)

[www.utahscientific.com](http://www.utahscientific.com)  
E-mail: [sales@utsci.com](mailto:sales@utsci.com)



4750 Wiley Post Way -- Suite 150  
Salt Lake City, Utah 84116  
Phone: +1 (801) 575-8801  
Fax: +1 (801) 537-3099

Via Filli Bandiera, 52  
20050 Verano Brianza (MI)  
Italy  
Phone: +39 0362 330 001

Thoroyaveien 11  
3209 Sandefjord  
Norway  
Phone: +47 33 522 700

REV. 0111