

# MC-400

## HD/SD Channel Branding System



The MC-400 HD/SD Channel Branding System represents a major evolution in the design and deployment of signal processing functionality for live and automated master control systems. The MC-400 can be used as a standalone system or as part of a multi-channel master control system under the control of an MC-2020 master control network.

The MC-400 takes full advantage of the unique I/O flexibility of the UTAH-400 digital routing switcher by placing the signal processing electronics on a single board that can be installed in an output slot of any UTAH-400 router frame. By using this approach, the processor is given full access to every signal available within the router, eliminating the need for external connections between the router and the control electronics.

The MC-400 allows the operator to change between SD and HD operation with a single menu selection, allowing the channel to be re-purposed for operation with various signal formats during the course of normal operations.

### MC-400 FEATURES

- PROCESSOR BOARD FITS INTO A UTAH-400 ROUTER OUTPUT SLOT
- DUAL KEYERS, SWITCHABLE BETWEEN INTERNAL, EXTERNAL, AND LOGO SOURCES
- EMBEDDED AUDIO PROCESSING, EXTERNAL AUDIO INPUT, ON-BOARD AUDIO CLIP STORAGE
- COMPREHENSIVE 2 RU CONTROL PANEL -- COMPATIBLE WITH MC-2020 CONTROL NETWORK
- EAS MESSAGE HANDLING OPTION

MC-400 Product Information Sheet

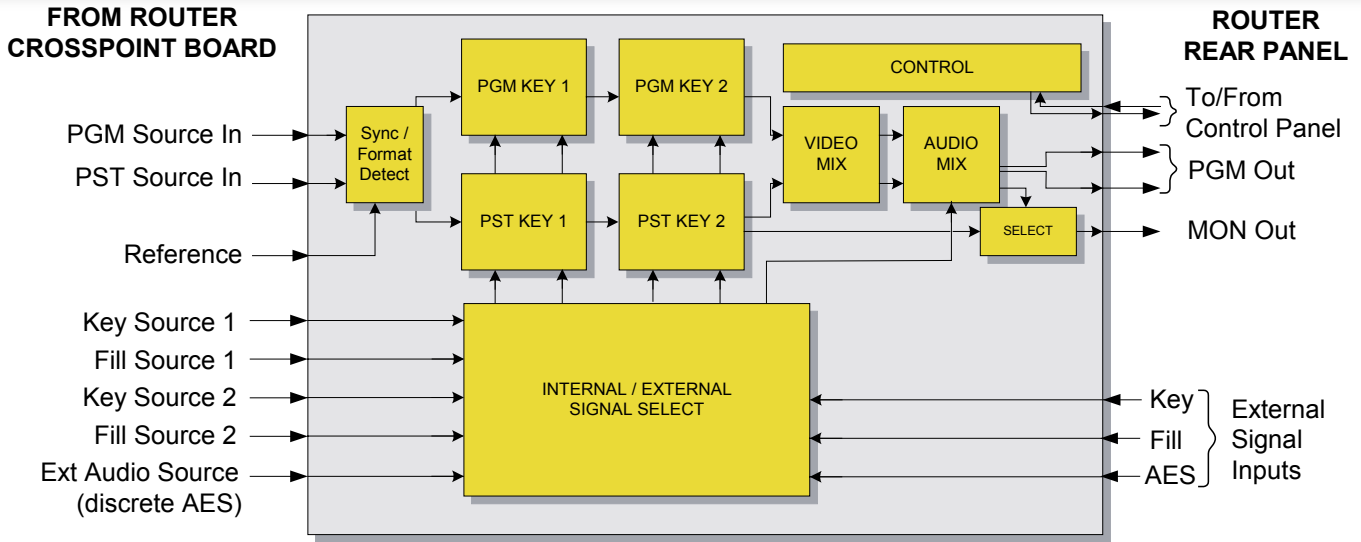

To accommodate signals such as key signals that may not be present in the router, external inputs are provided for all major signals. With this flexibility, system design can be greatly simplified.

The processor offers two fully independent keyers, each of which can be fed by internal or external signals or by an internal logo store. Likewise, audio voice-over mixing can come from an internal embedded audio signal, an external discrete AES digital audio signal, or an on-board audio clip storage facility. Logos and audio clips can be downloaded directly to the MC-400 or via the MC-2020 control network.

The 2RU control Panel for the MC-400 features a full set of operational controls for all MC-400 functions. In addition, the panel serves as the interface point for external signals such as automation, EAS, tally and GPI lines. The 1RU MCI-400 is used to provide these connections when the processor is used with a multi-channel control panel.

